

## MODEL 170, 202, 208

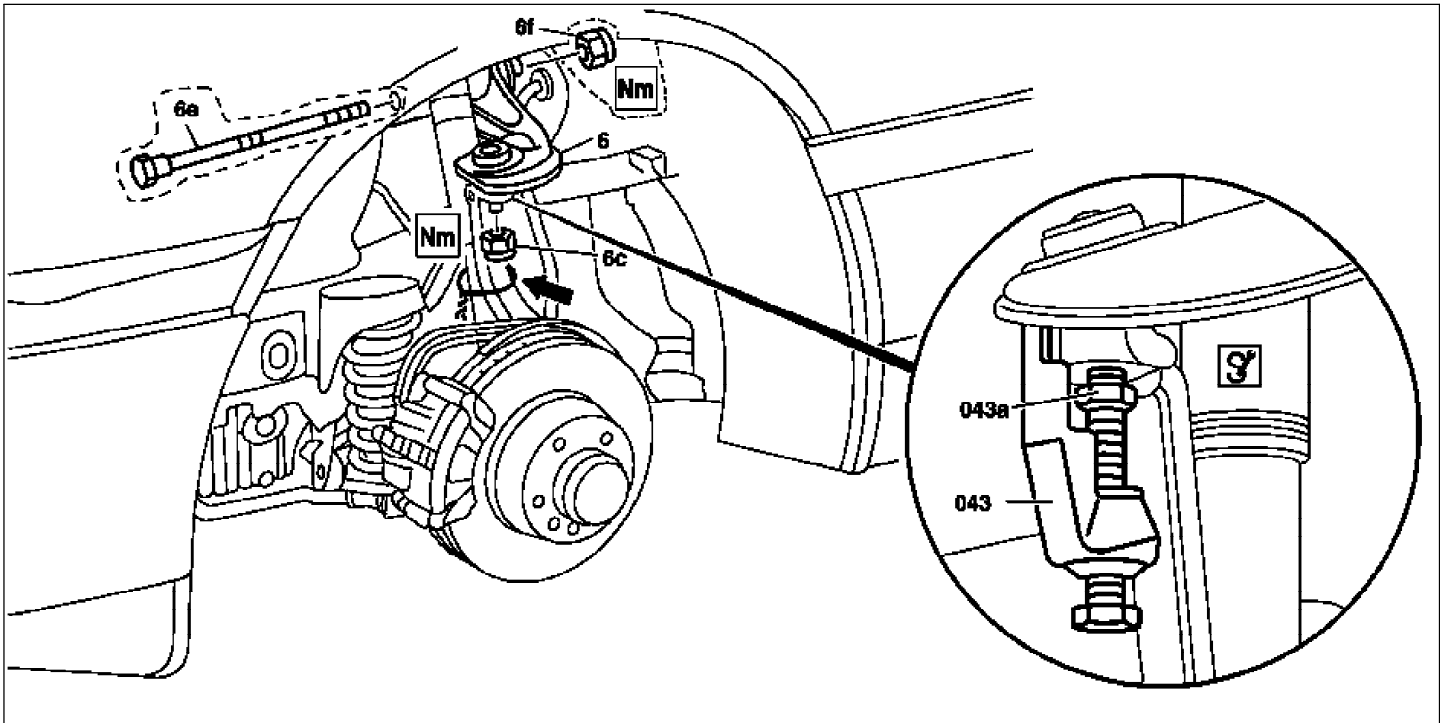

P33.20-0279-09

	Removal and installation		
	To remove the upper wishbone the shock absorber must be installed		
<b>Installation</b>	Replace self-locking bolts and nuts		
1	Unscrew nut (6c)		*BA33.20-P-1002-01A
2	Screw thrust piece (043a) onto the ball pivot of the follower joint		*210589046300
3	Using puller (043), press follower joint out of upper wishbone (6)	 Clean tapered connection	*124589033300
4	To prevent steering knuckle from tilting away, fasten it to the shock absorber with a piece of wire (arrow)	Do not subject brake hose and electric cables to tension.	
5.1	Remove left upper wishbone from frame	Tighten nut in ready-to-drive condition. 	*BA33.20-P-1007-01A
5.2	Remove right upper wishbone from frame	Tighten nut in ready-to-drive condition. Model 202 Model 170 : Remove air cleaner housing 	AR33.20-P-0500-03A *BA33.20-P-1007-01A
6	Check follower joint		AR33.20-P-0425A
7	Install in reverse order		

## Wheel location, wheel hub

Number	Designation		Model 170	Model 202	Model 208
BA33.20-P-1002-01A	Self-locking nut, follower joint of upper wishbone to steering knuckle	First time	Nm 45	45	45
		Check torque	Nm -	-	-
BA33.20-P-1007-01A	Self-locking nut, upper wishbone to front end		Nm 65	65	65

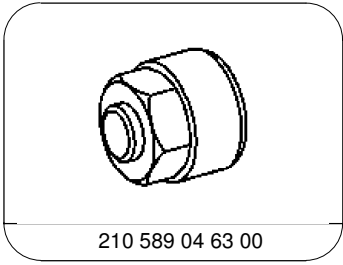

210 589 04 63 00

Thrust piece

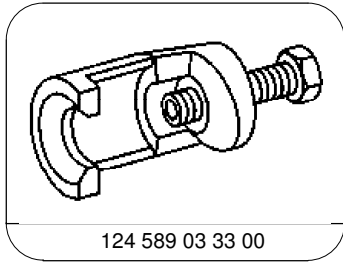

124 589 03 33 00

Puller